

# SILENT CHECK VALVES 1400\*

## WAFER STYLE • CAST IRON BODY

### 125 LB. CLASS • STAINLESS STEEL TRIM\*\*

1400	Conforms to MS SP-125, ANSI NSF-372
------	--

#### MATERIAL LIST

NO.	PART	MATERIAL
1	Body	Cast Iron
2	Seat	Stainless Steel
3	Disc	Bronze
4	Spring	Stainless Steel
5	Bushing	Bronze
6	Screw	Stainless Steel

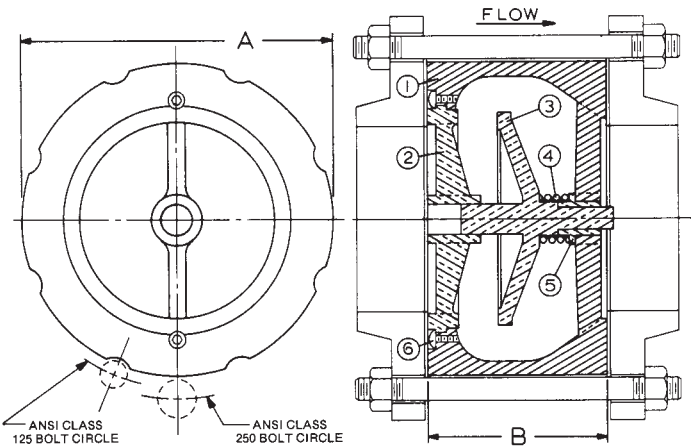

#### DIMENSIONS - INCHES / MILLIMETERS

Units	Size	Weight Lbs.	A	B	C <sub>v</sub>
Inches	2	6	4.25	2.63	66
mm	50.8		108.0	66.7	
Inches	2 1/2	7	5.00	2.88	88
mm	63.5		127.0	73.0	
Inches	3	12	5.75	3.13	130
mm	76.2		146.1	79.4	
Inches	4	18	7.00	4.00	228
mm	101.6		177.8	101.6	
Inches	5	27	8.38	4.63	350
mm	127.0		212.7	117.6	
Inches	6	42	9.75	5.50	520
mm	152.4		247.7	139.7	
Inches	8	85	13.38	6.50	900
mm	203.2		339.7	165.1	
Inches	10	146	16.00	8.25	1450
mm	254.0		406.4	209.6	

#### PRESSURE TEMPERATURE RATINGS

TEMP. DEG. F.	MAX., NON-SHOCK SERVICE PRESS.			
	ANSI B16.1 FLG. RATINGS			
	125 LB CLASS		250 LB CLASS	
	2" - 12"	14" - 42"	2" - 12"	11" - 42"
0° - 150°	200	150	400	300
200°	190	135	370	280

TEST PRESSURE	300	230	600	450
---------------	-----	-----	-----	-----

#### DIMENSIONS - INCHES / MILLIMETERS

Units	Size	Weight Lbs.	A	B	CV
-------	------	-------------	---	---	----

SIZES 2" THRU 6" ARE COMBINATION ANSI CLASS 125 AND 250, VALVES USE ANSI CLASS 125

Inches	8	86	13.38	6.50	900
mm	203.2		339.7	165.1	
Inches	10.00	137	16.00	8.25	1450
mm	254.0		406.4	209.6	

Rev. 10

\* International Valve

\*\*Bronze trim available upon request. Consult factory.  
Will not meet ANSI NSF-372

NOTE: Stainless Steel trim recommended for temperatures 180° - 200° F.

Valve is designed for liquid service only. Install 5 to 10 pipe diameters downstream from pump discharge or elbows to avoid flow turbulence. Valve is designed to be mated to standard steel flanges.

**INNOVATION** IN EVERY VALVE



**MILWAUKEE VALVE**

The information presented on this sheet is correct at the time of publication. Milwaukee Valve reserves the right to change design, and/or material specifications without notice. For the Installation, Operation and Maintenance Manual (IOM) see the engineering section on our website. For the most current information access [www.milwaukeevalve.com](http://www.milwaukeevalve.com)

[www.milwaukeevalve.com](http://www.milwaukeevalve.com)